

SR04 SERIES MOTORIZED VALVE

DESCRIPTION

SR04 series motorized valves are used to control the opening or closing for the pipe in the chilled/hot water system so to control the room temperature. The valve is driven by hysteresis synchronous motor with spring return. The valve is normal-closed. When the thermostat is working, it will provide an opening signal, and the motorized valve will be turned on to open. Then the chilled/hot water will enter into the coil and supply the cold/hot to the room. When the room temperature rises up to the set point, the thermostat will make the valve power off. At the same time the valve will be closed by return spring and the water to the coil will be shut off. The room temperature will be kept in the setting range all the time through the opening and closing of the valve.



SR04 series motorized valve has two types: normal-closed 2-way and diverting 3-way. It has three sizes: 1/2", 3/4" and 1". There are eight kinds of specifications classified by the access type and the fluid characteristic.

SR04 series motorized valve is flexible, reliable, long-life and low noise. It is designed to withstand high temperature condition in many concealed fan coil applications. The installation work is very simple.

MODEL SELECTION

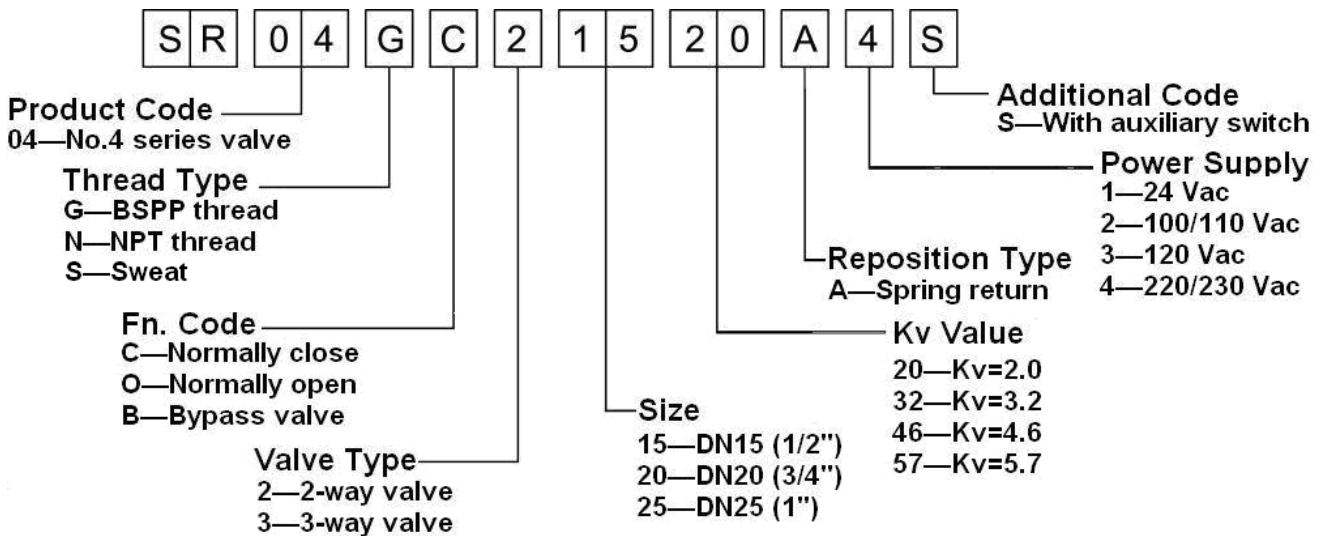

SPECIFICATIONS AND DATA:

MODEL	TYPE	SIZE	CONN.	Kv	CLOSING -OFF PRES. (MPa)	RATING PRES. (MPa)	MEDIUM	FLUID TEMP.	AMBIENT TEMP.	POWER SUPPLY
SR04GC21520A4	Normally close 2-Way	DN15	G1/2	2.0	0.20	2.1	Chilled/ Hot water	2~ 94°C	<40°C	220V±10%; 50~60Hz
SR04GC21532A4	Normal ly close 2-Way	DN15	G1/2	3.2	0.15					
SR04GB31543A4	Diverting 3-Way	DN15	G1/2	4.3	0.10					
SR04GC22020A4	Normally close 2-Way	DN20	G3/4	2.0	0.20					
SR04GC22032A4	Normally close 2-Way	DN20	G3/4	3.2	0.15					
SR04GB32046A4	Diverting 3-Way	DN20	G3/4	4.6	0.10					
SR04GC22557A4	Normal ly close 2-Way	DN25	G1	5.7	0.10					
SR04GB32557A4	Diverting 3-Way	DN25	G1	5.7	0.10					

* There is auxiliary switch (250Vac/3A) for choice.

* All the data will be changed without prior notice.

Dimensions

Type	Dimensions (mm)					
	A	B	C	D	E	F
2-way DN15	76	60	54	100	76	38
3-way DN15				110		
2-way DN20				100	80	38
3-way DN20				110		
2-way DN25				102	84	41
3-way DN25				118		

INSTALLATION AND OPERATION INSTRUCTION

Normal-closed 2-way and diverting 3-way valve are installed as Figure 1, 2 and 3. For high building, pressure-reducing valve should be installed on branch pipe at ground floor.

Note: When the valve is mounted on horizontal pipe, the angle must be positioned less than 85° (see Figure 4).

When the valve is mounted on vertical pipe, it must be prevented from dripping.

Manual operating lever: Move the manual operating lever slowly and hold in the retaining notch, and then the valve is in normal-opened position. When the valve is first powered on, the lever goes back to the automatic position again.

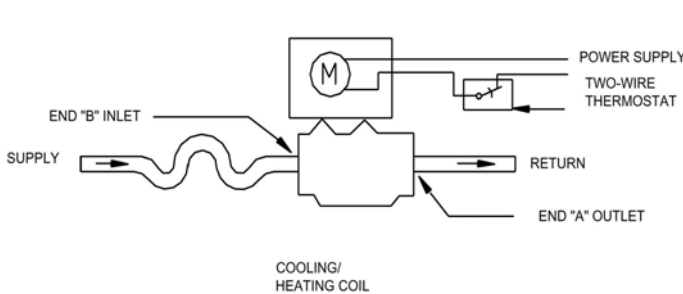

Fig. 1 Two-way valve

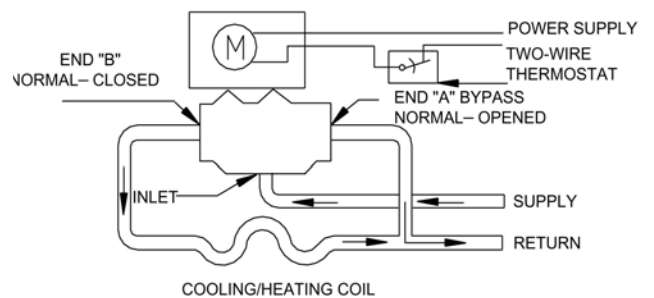

Fig. 2 Three-way valve

When install normal-closed 2-way valve, the flow direction is from end "B" to "A", for normal-open valve, it is from end "A" to "B". In both situations, the valve closing direction is opposite.

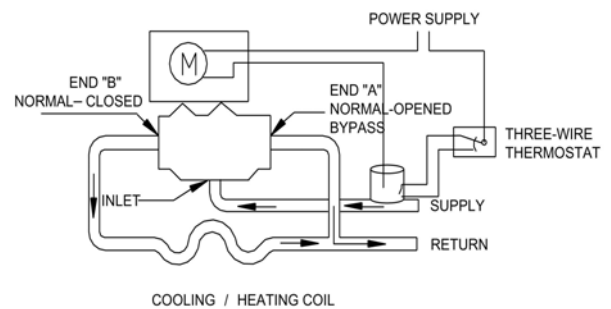
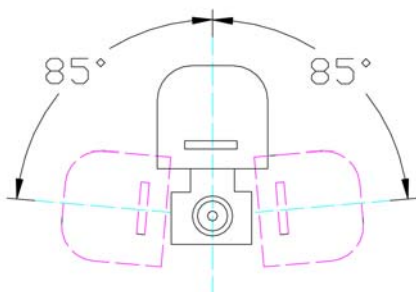

Fig. 3 Three-way valve with box change-over switch

When install diverting 3-way valve, end "B" is supply to the coil, end "A" is by-pass, there is no mark for inlet, end "A" and "B" is marked on the bottom of the valve.